

# CUPV60M

290W/295W/300W/  
305W/310W/315W/  
320W

MONO CRYSTALLINE MODULE

IEC61215 / IEC61730 / IEC61701 /  
IEC62716 / IEC62804

Power  
Space  
Technology

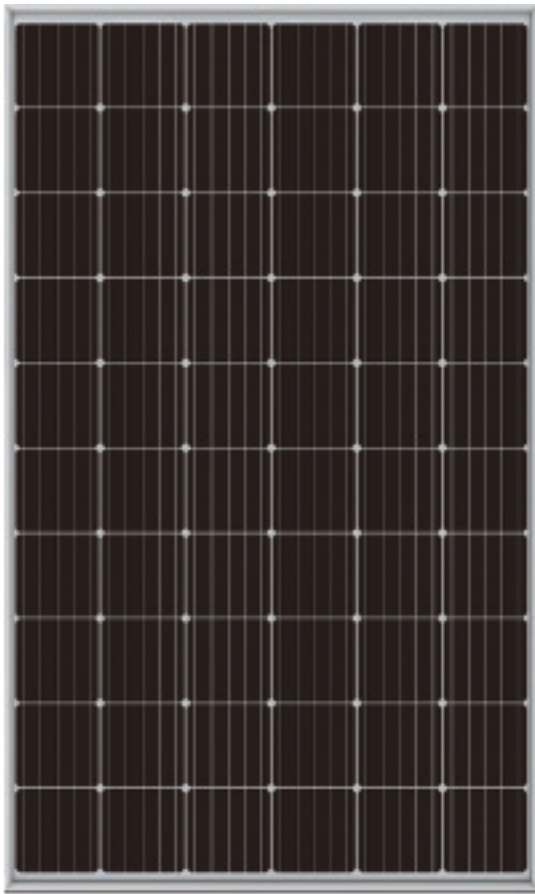

### IP68 junction box, connector

IP68 junction box and connector have a high degree of waterproof, effectively resist the harsh environment;



### 15A current

The junction box carries a current of 15A, ensuring high current flow through the modules;



### Super strong frame

Glue-spilled tank has a double-layer waterproof, cross-section with hook-shaped aluminum frame, enhanced by 10% of the mechanical load strength;



### Current division

The module refines the current division, thus effectively reducing the loss of up to 2% due to mismatch and increasing the power output of the system;



### Salt spray, ammonia and PID test

Excellent salt spray resistance, anti-ammonia and anti PID, TUV, SUD certification approved;



### Strong mechanical load capacity

Passed the 2400pa wind load and 5400pa snow load test, ensuring that the module has a stable mechanical life;



### Color classification

Modules are packaged according to color classification, to achieve consistent appearance after installation;

### LINEAR PERFORMANCE WARRANTY

- 12 Years Manufacturing Warranty
- 12 Years 90% Power Output
- 25 Years 80% Power Output

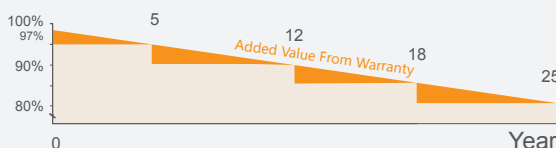

### QUALIFICATIONS AND CERTIFICATES



MECHANICAL DRAWINGS

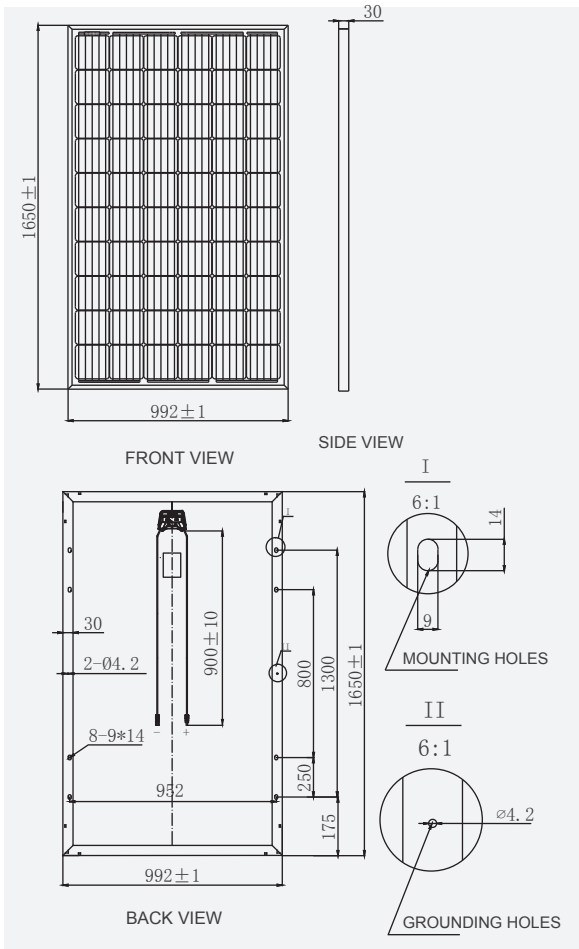

MECHANICAL SPECIFICATION

Cell Type	Mono Crystalline 156.75x156.75mm
Number Of Cells	60 (6x10)
Dimensions(AxBxC)	1650x992x30mm
Weights	18.5kg
Front Glass	3.2mm Tempered Low Iron Glass
Frame	Clear Anodized Aluminum Alloy
Junction Box	IP68,with Bypass Diodes
Connector	Mc4 Compatible
Output Cables	Tuv,±length 900mm,4.0mm <sup>2</sup>

ELECTRICAL CHARACTERISTICS

Maximum Power At STC(Pmax)	290W	295W	300W	305W	310W	315W	320W
Short Circuit Current(Isc)	9.58A	9.72A	9.78A	9.89A	9.96A	10.05A	10.14A
Open Circuit Voltage(Voc)	39.2V	39.6V	39.8V	40.1V	40.3V	40.6V	41.0V
Maximum Power Current(Imp)	8.95A	9.08A	9.17A	9.30A	9.40A	9.49A	9.58A
Maximum Power Voltage(Vmpp)	32.4V	32.5V	32.7V	32.8V	33.0V	33.2V	33.4V
Module Efficiency	17.72%	18.02%	18.33%	18.63%	18.94%	19.24%	19.55%
Power Tolerance	0~+3%	0~+3%	0~+3%	0~+3%	0~+3%	0~+3%	0~+3%

STC: 1000W/m<sup>2</sup> irradiance, 25°C cell temperature, AM1.5.

NOCT

Maximum Power At STC(Pmax)	216.2	219.9	223.6	227.4	231.1	234.8	238.5
Short Circuit Current(Isc)	7.76	7.87	7.92	8.01	8.06	8.14	8.21
Open Circuit Voltage(Voc)	36.2	36.6	36.8	37.1	37.3	37.5	37.9
Maximum Power Current(Imp)	7.35	7.46	7.51	7.59	7.64	7.71	7.78
Maximum Power Voltage(Vmpp)	29.4	29.5	29.8	30.0	30.2	30.4	30.7

NOCT: Irradiance at 800W/m<sup>2</sup>, Ambient Temperature 20°C, wind speed 1m/s.

I-V CURVES

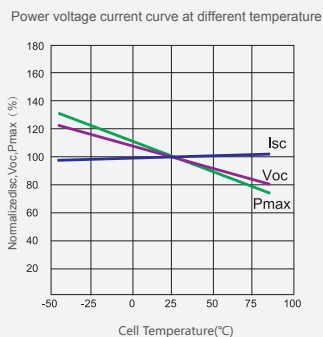
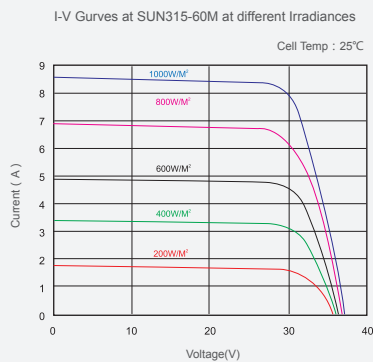

SYSTEM INTEGRATION PARAMETERS

Maximum System Voltage	VDC 1000V
Maximum Series Fuse	15A
Increased Snowload Acc.to Iec 61215	5400Pa
Operating Temperature	-40~+85°C
Number Of Bypass Diodes	3

TEMPERATURE CHARACTERISTICS

Normal Operating Cell Temperature(Noct)	45°C±2°C
Temperature Coefficient Of Pmax	-0.40%/°C
Temperature Coefficient Of Voc	-0.29%/°C
Temperature Coefficient Of Isc	0.05%/°C

PACKING CONFIGURATION

	20' GP	40' GP/40' HQ
Container		
Pieces Per Pallet	35	35/35
Pallets Per Container	14	28/28
Pieces Per Container	468	980/1050